

ILLUSTRATED PARTS LIST FOR N-C CARPET SERGING MACHINE

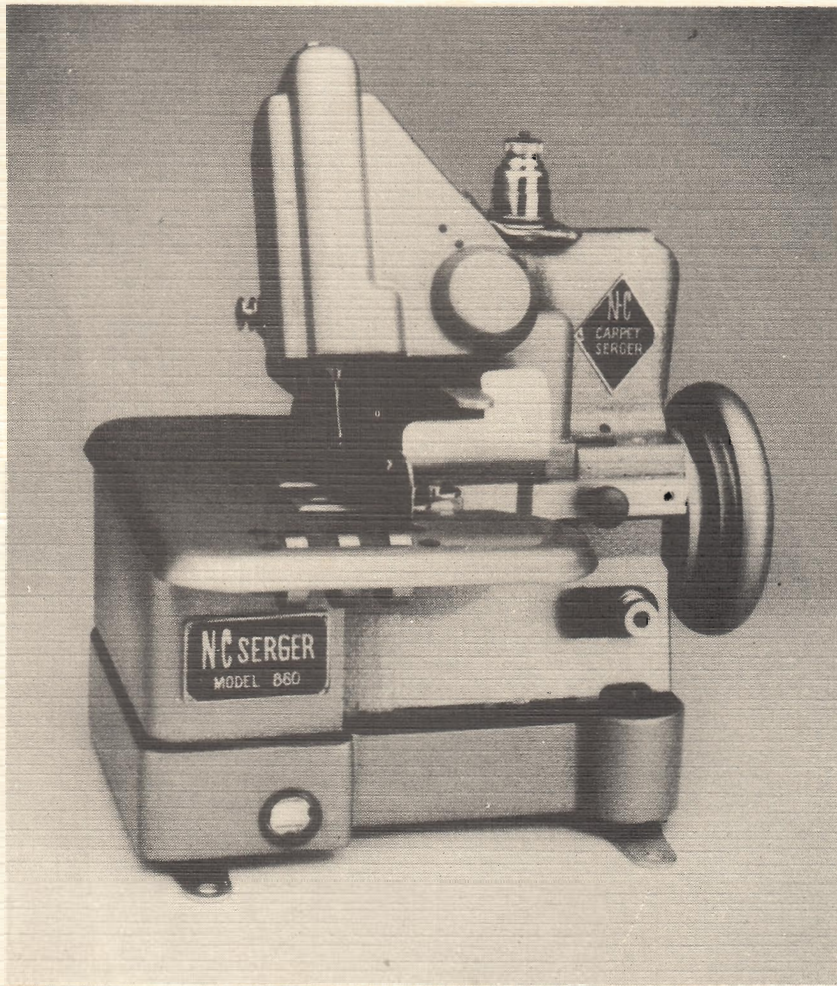

NC MODEL'S #860 - 860T



N-C CARPET BINDING & EQUIPMENT CORP.

858 Summer Avenue, Newark, New Jersey 07104

PHONE: 973-481-3500 • TOLL FREE 1-800-526-1184

FROM CANADA: 1-800-336-1184 • FAX: 973-481-0839

Web site: <http://www.n-ccarpet.com>

INDEX

GENERAL INSTRUCTIONS.	Page 3
THREADING INSTRUCTIONS	" 4 & 5
STITCH REGULATE AND LOOPER ADJUSTMENT	" 6
ILLUSTRATED LIST OF PARTS.	" 7
PLATE No. 1 Covers and brackets.	" 8 & 9
PLATE No. 2. Base and inside covers	" 10 & 11
PLATE No. 3. Tensions and take-ups.	" 12 & 13
PLATE No. 4. Needle bar mechanism	" 14 & 15
PLATE No. 5. Presser foot mechanism	" 16 & 17
PLATE No. 6. Feeding mechanism	" 18 & 19
PLATE No. 7. Looper mechanism	" 20 & 21
PLATE No. 8. Cam, bushings and shaft	" 22 & 23
PLATE No. 9. Lubrication parts	" 24 & 25
PLATE No. 10. Special Parts	" 26 & 27
PARTS NUMBER INDEX.	" 28

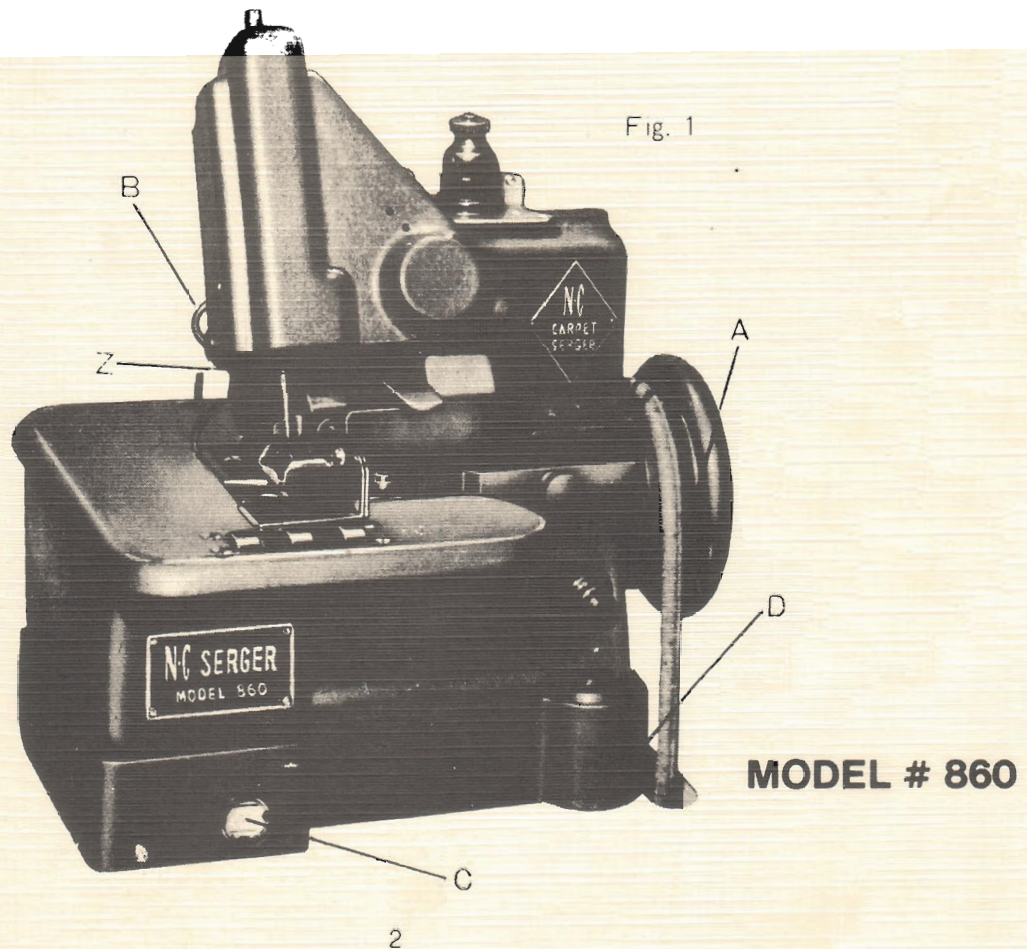

GENERAL INSTRUCTIONS

The N - C CARPET SERGING machine is used for overedging carpets of all description including foam rubber back carpets.

The all new N - C CARPET SERGER has been produced after careful research into the problems of carpet serging. It has an improved pump type force-feed oil system that insures proper lubrication of all the internal moving parts. With proper maintenance the N - C CARPET SERGER will give you years of trouble free service.

SETTING UP YOUR N - C CARPET SERGER

a N - C CARPET SERGER should be set up using a $\frac{1}{3}$ H.P. motor.

A 3 $\frac{1}{2}$ " pulley should be used with motors that run at 1725 R.P.M.

b- N - C CARPET SERGER should be set up so the belt groove on the balance wheel (A, fig. 1) is in line with the belt groove on the motor pulley.

c- Fasten the N - C CARPET SERGER securely to the table top using wood screws.

d- Connect belt from balance wheel to motor pulley.

e- Connect chain to foot lifting lever (B, fig. 1).

f- Fill oil reservoir with good grade of oil so that indicator gauge (C, fig. 1) is at full level.

There is an oil drain plug (D, fig. 1) directly under the balance wheel. Drain machine at least every three (3) months to keep a clean supply of oil in the machine so that the oil pump does not become clogged.

CAUTION: OIL RESERVOIR MUST BE KEPT AT PROPER LEVEL TO AVOID DAMAGE TO THE MACHINE NEEDLES.

a- N - C CARPET SERGERS require chrome plated needle,

N - C System 103-14 Size 23

b- TO SET NEEDLE-loosen needle clamping nut (Z, fig. 1) put needle into needle bar as far as it will go, with the long groove and eye of needle facing towards you. Then retighten nut.

THREADING CHART

Fig. 2

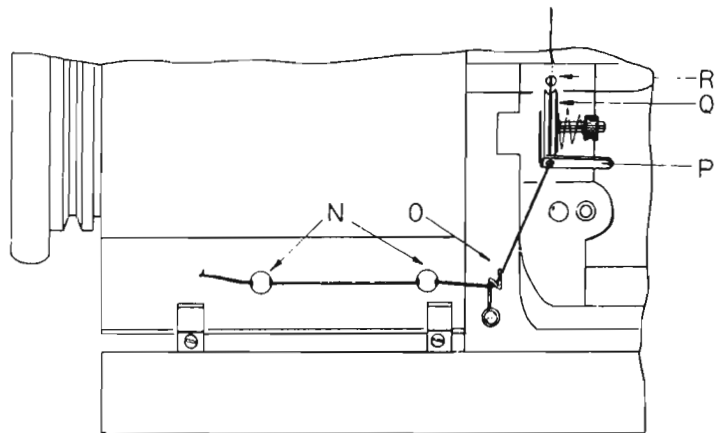
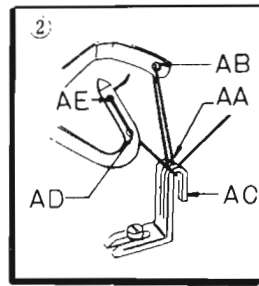
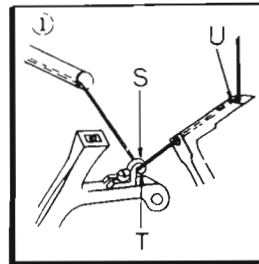
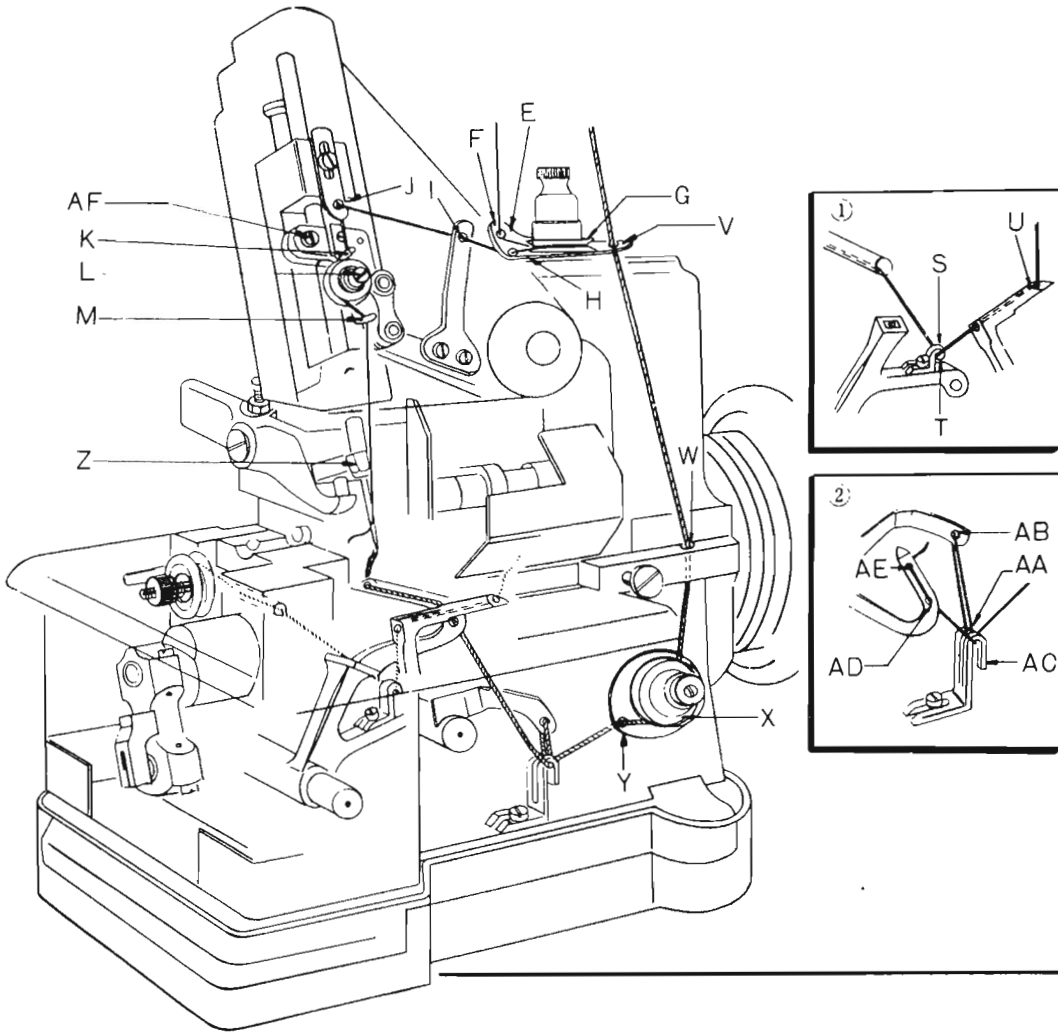

BACK VIEW

THREADING THE MACHINE

1. TO THREAD THE NEEDLE, open the swing face plate. Pass thread from thread stand holder through hole (E, fig. 2) then back through hole (F, fig. 2), around front and between tension discs (G, fig. 2) and through hole (H, fig. 2); then from back to front of needle thread take-up (I, fig. 2) through eyelet (J, fig. 2), to right of stud (K, fig. 2) on needle bar thread retainer bracket, around left between retainer discs (L, fig. 2) down through guide (M, fig. 2) and through eye of needle from front to back.
2. TO THREAD THE LEFT HAND LOOPER, (Part No. 37076)-Open swing cloth plate.-Pass thread from thread stand holder down through eyelet hole (N, fig. 2) through left hand looper thread guide (O, fig. 2) under lower thread bracket arm (P, fig. 2) then up and over and between tension discs (Q, fig. 2) and through thread tube (R, fig. 2) then from back to front through looper eyelet (S, fig. 2) into hole (T, fig. 2) in rear of looper and from front to back through eye of looper (U, fig. 2)
3. TO THREAD RIGHT HAND LOOPER (Part No. 37832)-Open frame side cover. Pass thread from thread stand holder down through tension plate hole (V, fig. 2) then down through chip guard extension bracket hole (W, fig. 2) around and between tension discs (X, fig. 2) and through guide plate hole (Y, fig. 2) from back to front under rear prong of looper staple (AA, fig. 2) from back to front through take-up (AB, fig. 2) then down under front prong of looper staple (AC, fig. 2), then up and from back to front through hole (AD, fig. 2) in heel of right hand looper and from front to back through eye (AE, fig. 2) of right hand looper.

TO REGULATE THE LENGTH OF STITCH

The length of stitch is regulated by the feed regulator. Using wrench supplied, loosen feed regulator stud. To decrease length of stitch move regulator downward; to increase length of stitch move regulator upward; retighten feed regulator stud securely.

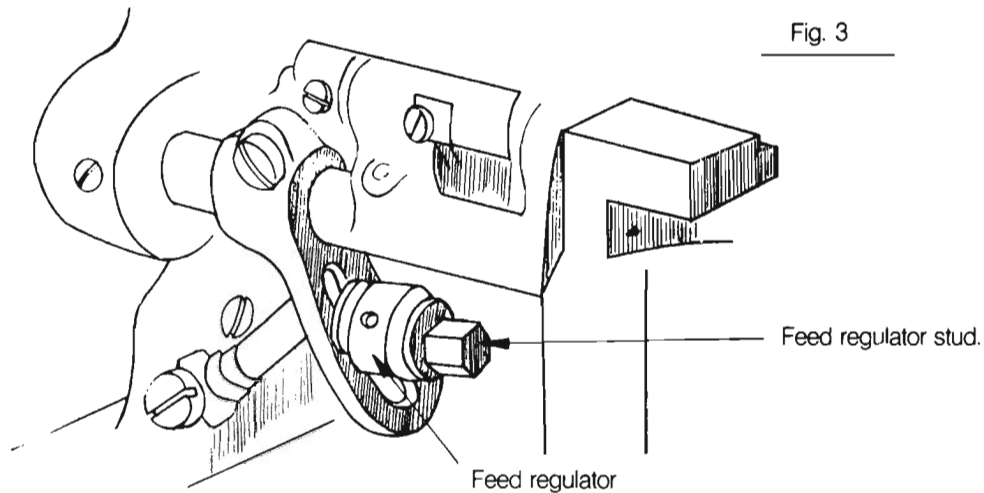

REPLACING AND RESETTING LOOPERS

1. TO REPLACE OR RESET THE LEFT HAND LOOPER-remove needle plate.
 - a - Turn balance wheel until the needle bar is in its lowest position.
 - b - the point of the looper should be approx. 1/8 inch to the left of needle.
 - c - raise the needle bar, by turning balance wheel, until the needle bar rises 3/32" from its lowest position, and the point of the looper should be at the center of the needle.
 - d - left hand looper should be set in looper carrier by means of screw (7302, fig. 4), so that it passes as close as possible to the needle without striking it, on its loop taking stroke.
2. TO REPLACE OR RESET THE RIGHT HAND LOOPER-Set looper on right hand looper holder, replace and tighten screw (1196, fig. 4). The right hand looper point should pass at the recess back of the left hand looper eye as closely as possible without touching it.
3. TO REPLACE OR RESET NEEDLE BAR-Remove needle plate. Turn balance wheel until needle bar has risen 3/32" from its lowest position, the point of the left hand looper, on its loop taking stroke, should be at center of the needle, and the eye of the needle should be about 1/16" below looper point. To adjust needle bar loosen screw (AF, fig. 2), adjust bar to proper position and retighten screw (AF, fig. 2) securely.

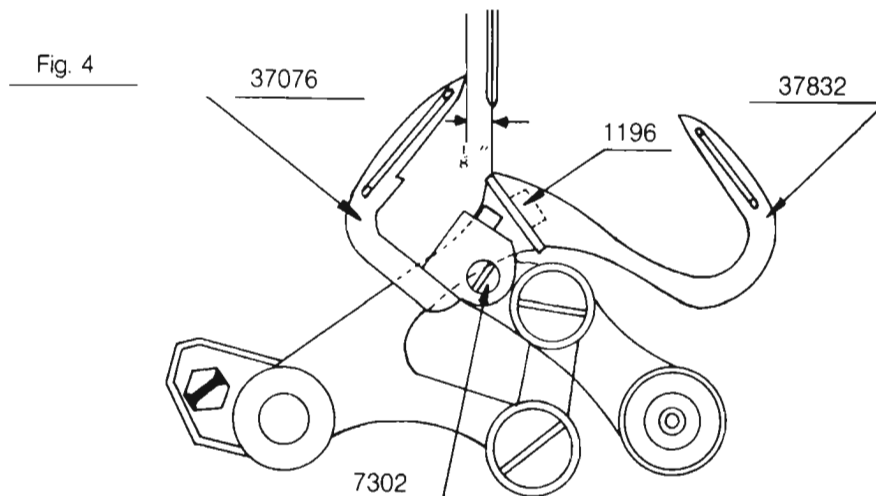

**ILLUSTRATED
LIST OF PARTS
MODEL - #860**

PLATE No.1

COVERS AND BRACKETS

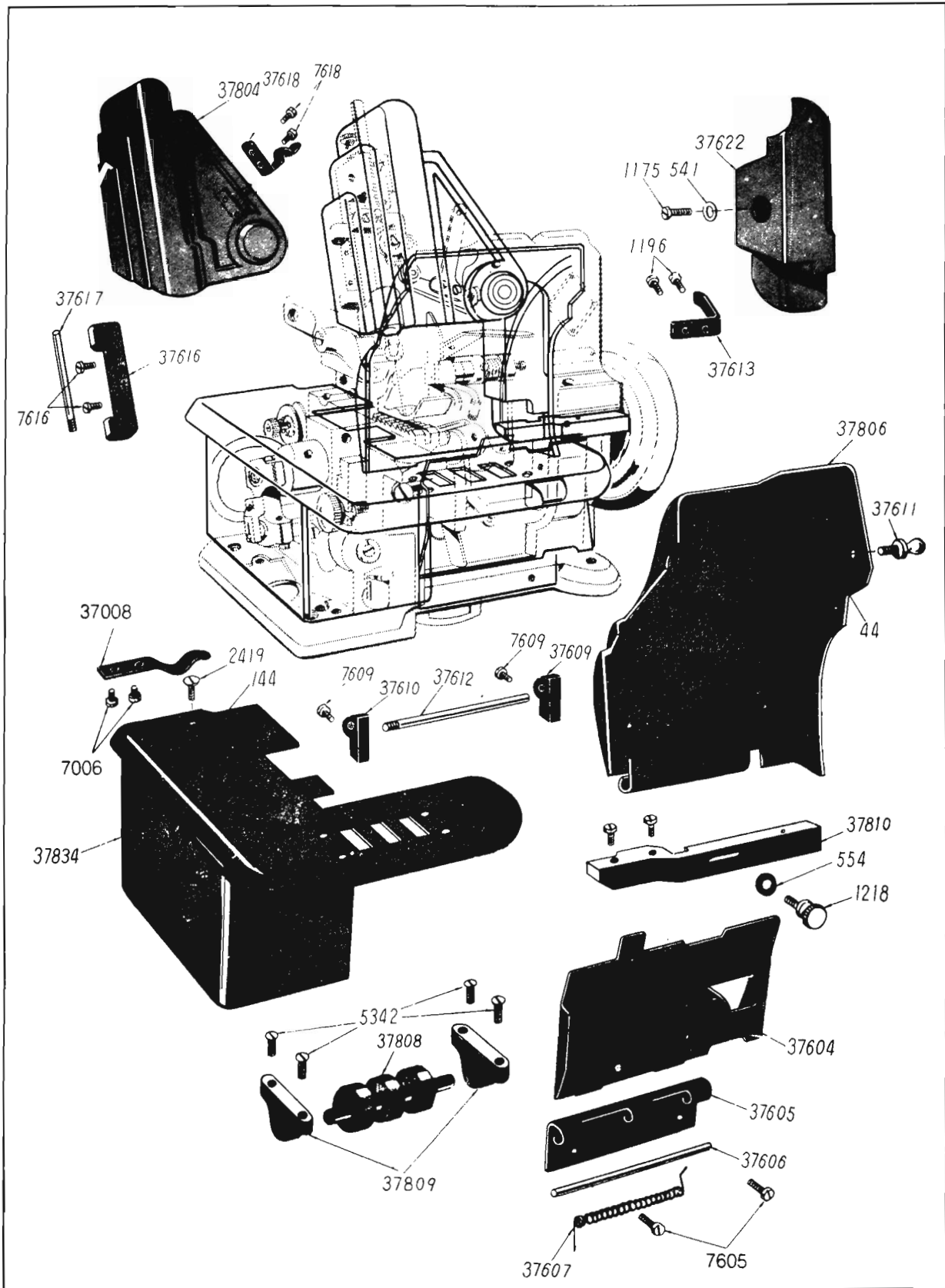

PLATE No. 1

N	44	Frame back cover opening knob nut.
N	144	Cloth plate hinge screw nut.
N	541	Needle bar connecting rod (front) cover washer.
N	554	Chip guard extension holder washer.
N	1175	Needle bar connecting rod (front) cover screw.
N	1196	Frame back cover spring set screw.
N	1218	Chip guard extension holder thumb screw.
N	2419	Cloth plate hinge screw.
N	5342	Cloth plate roller bracket set screw.
N	7006	Cloth plate lock spring screw.
N	7605	Frame side cover bracket set screw.
N	7609	Frame back cover bracket set screw.
N	7616	Arm front cover bracket set screw.
N	7618	Arm front cover spring set screw.
N	37008	Cloth plate lock spring.
N	37604	Frame side cover.
N	37605	Frame side cover bracket.
N	37606	Frame side cover bracket hinge pin.
N	37607	Frame side cover bracket spring.
N	37609	Frame back cover bracket (right).
N	37610	Frame back cover bracket (left).
N	37611	Frame back cover opening knob.
N	37612	Frame back cover bracket hinge pin.
N	37613	Frame back cover spring.
N	37616	Arm front cover bracket.
N	37617	Arm front cover bracket hinge pin.
N	37618	Arm front cover spring.
N	37622	Needle bar connecting rod (front) cover.
N	37804	Arm front cover.
N	37806	Frame back cover.
N	37808	Cloth plate roller.
N	37809	Cloth plate roller bracket.
N	37810	Chip guard extension holder.
N	37834	Cloth plate.

PLATE No.2

BASE AND INSIDE COVERS

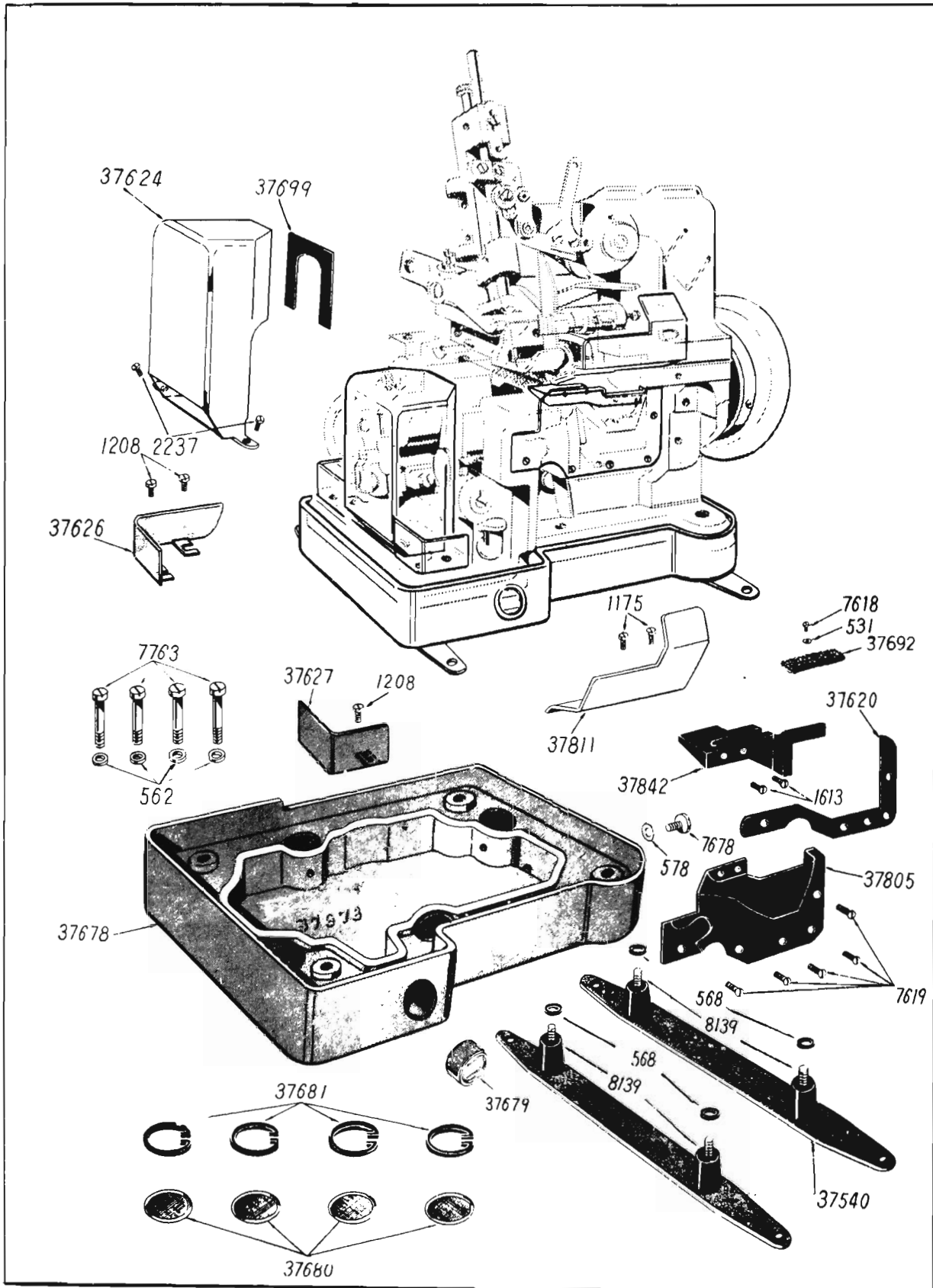

PLATE No. 2

N	531	Front cover felt washer.
N	562	Machine base attaching screw washer.
N	568	Machine base cushion washer.
N	578	Machine base oil drain gasket.
N	1175	Chip guard set screw.
N	1208	Angle cover set screw.
N	1613	Worm cover set screw.
N	2237	Looper (right hand) connection cover screw.
N	7618	Front cover felt screw.
N	7619	Frame front cover (inner) set screw.
N	7678	Machine base oil drain screw.
N	7763	Machine base attaching screw.
N	8139	Machine base cushion.
N	37540	Machine base cushion holder plate.
N	37620	Frame front cover (inner) gasket.
N	37624	Looper (right hand) connection cover.
N	37626	Angle cover (large).
N	37627	Angle cover (small).
N	37678	Machine base.
N	37679	Oil sight gauge.
N	37680	Round oil filter screen.
N	37681	Round oil filter screen clamp.
N	37692	Front cover felt.
N	37699	Looper (right hand) connection cover gasket.
N	37805	Frame front cover (inner).
N	37811	Chip guard.
N	37842	Worm cover.

PLATE No.3

TENSIONS AND TAKE-UPS

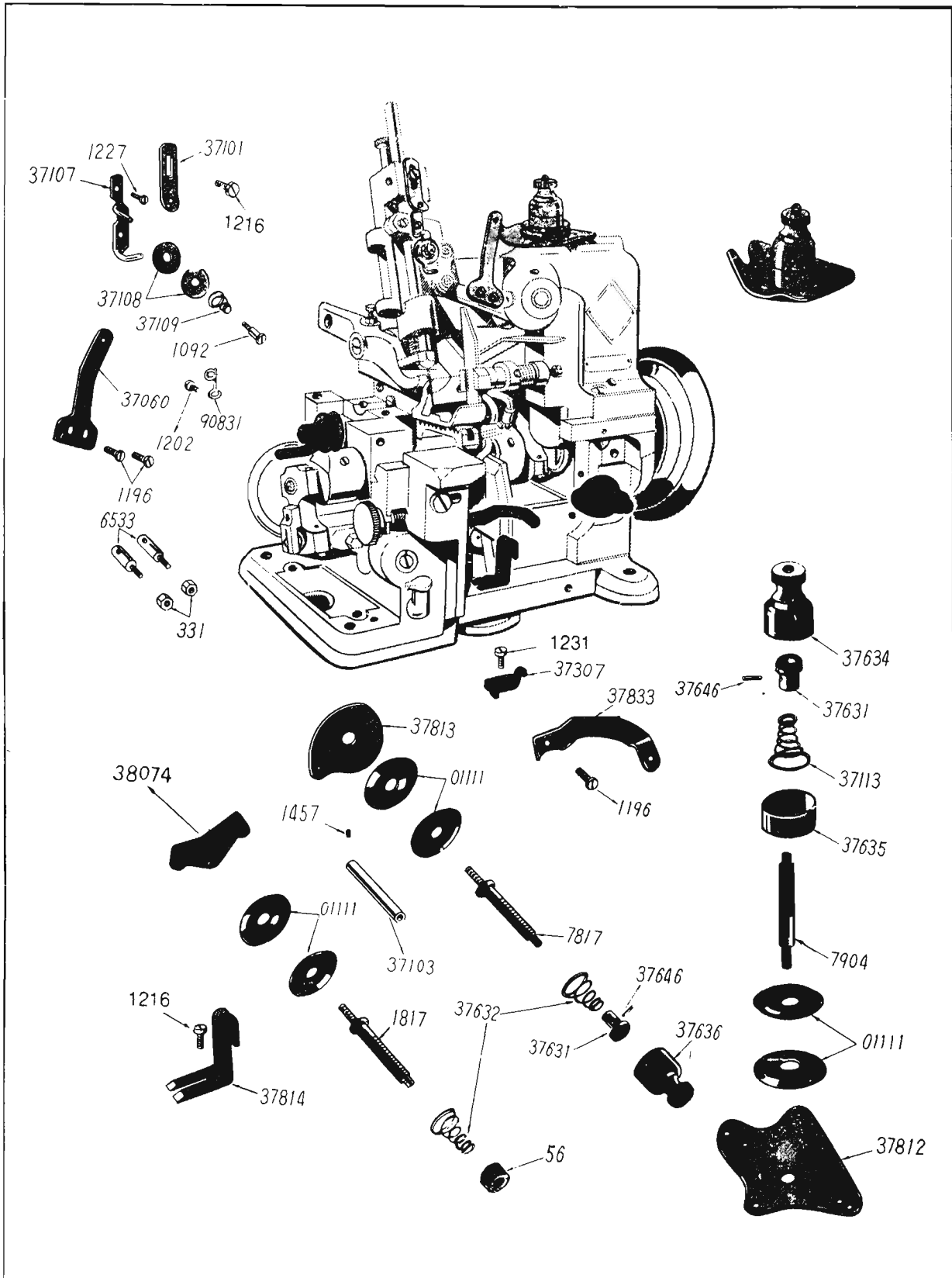

PLATE No. 3

N	56	Tension (left hand looper) regulating thumb nut.
N	331	Frame back cover thread eyelet nut.
N	1092	Needle bar thread retainer screw.
N	1196	Thread (needle) take-up screw.
N	1202	Thread (left hand looper) guide set screw.
N	1216	Thread (needle) eyelet set screw.
N	1216	Thread (right hand looper) staple set screw.
N	1227	Needle bar thread retainer bracket screw.
N	1231	Thread (left hand looper) eyelet set screw.
N	1457	Thread (left hand looper) tube set screw.
N	1817	Thread (left hand looper) tension stud.
N	6533	Frame back cover thread eyelet.
N	7817	Tension (right hand looper) stud.
N	7904	Tension (needle thread) stud.
N	01111	Tension disc.
N	37060	Thread (needle) take-up.
N	37101	Thread (needle) eyelet.
N	37103	Thread (left hand looper) tube.
N	37107	Needle bar thread retainer bracket.
N	37108	Needle bar thread retainer disc.
N	37109	Needle bar thread retainer spring.
N	37113	Tension (needle thread) spring.
N	37307	Thread (left hand looper) eyelet.
N	37631	Tension regulating spring bushing.
N	37632	Tension (looper thread) spring.
N	37634	Tension (needle thread) spring cap.
N	37635	Tension (needle thread) spring lower cap.
N	37636	Tension (right hand looper thread) spring cap.
N	37646	Tension regulating spring bushing pin.
N	37791	Tension (left hand looper) thread bracket.
N	37812	Tension (needle thread) thread guide plate.
N	37813	Tension (right hand looper) thread guide plate.
N	37814	Thread (right hand looper) staple.
N	37833	Thread (right hand looper) take-up.
N	90831	Thread (left hand looper) guide.

PLATE No.4

NEEDLE BAR MECHANISM

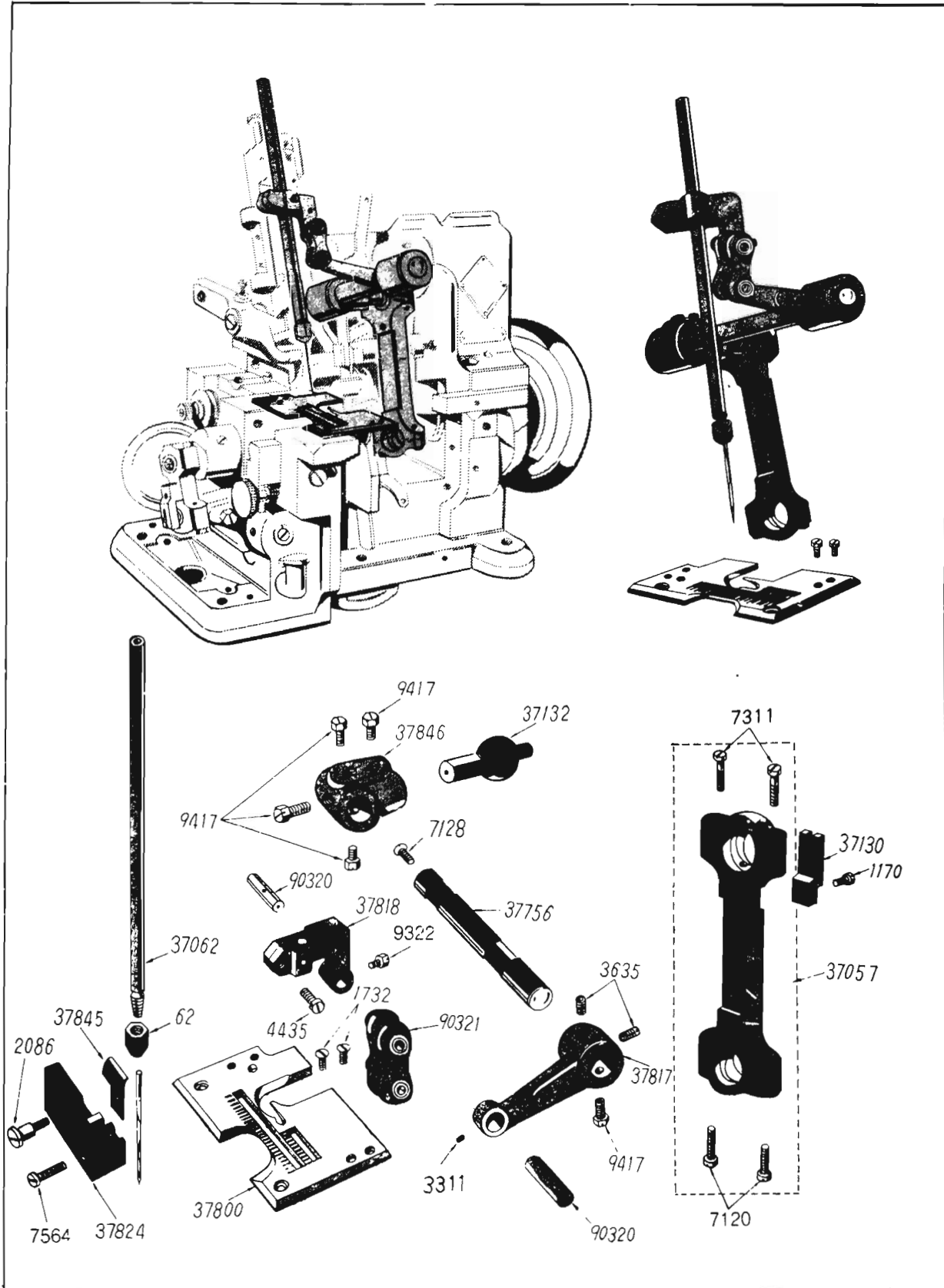

PLATE No. 4

N	62	Needle clamping nut.
N	1170	Needle bar connecting rod guide set screw.
N	1732	Throat plate screw.
N	2086	Needle guard bracket screw.
N	3635	Needle bar crank set screw.
N	4435	Needle bar connecting bracket screw.
N	4442	Needle bar connecting link hinge pin set screw for 37817
N	7120	Needle bar connecting rod lower cap screw.
N	7128	Needle bar crank shaft cap screw.
N	7311	Needle bar connecting rod upper cap screw.
N	7564	Needle guard screw
N	9322	Needle bar connecting link hinge pin set screw for 37818.
N	9417	Needle bar crank set screw. (hex head).
N	37057	Needle bar connecting rod complete set.
N	37062	Needle bar.
N	37130	Needle bar connecting rod guide.
N	37132	Needle bar connecting rod ball stud.
N	37756	Needle bar crank shaft.
N	37800	Throat plate.
N	37817	Needle bar crank (front).
N	37818	Needle bar connecting bracket.
N	37824	Needle guard bracket.
N	37845	Needle guard.
N	37846	Needle bar crank (rear).
N	90320	Needle bar connecting link hinge pin.
N	90321	Needle bar connecting link.

PLATE No.5 PRESSER FOOT MECHANISM

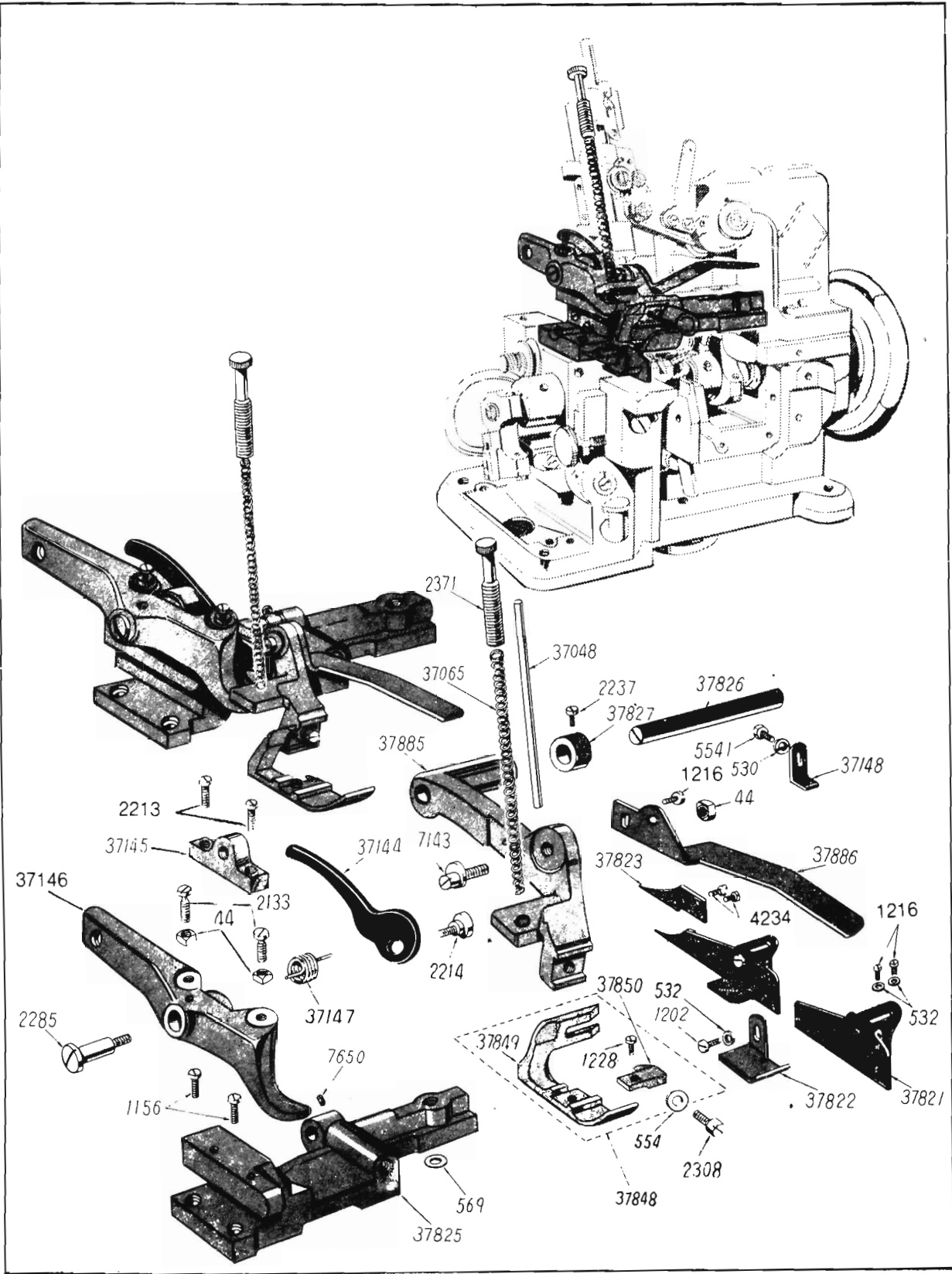

PLATE No. 5

N	44	Lifting lever stop screw nut.
N	44	Presser lever screw stud eccentric nut.
N	530	Presser lever stopper screw washer.
N	532	Cloth guide screw washer.
N	554	Presser foot screw washer.
N	569	Feed lifting bracket gasket.
N	1156	Feed lifting bracket set screw.
N	1202	Auxiliary cloth guide screw.
N	1216	Cloth guide screw.
N	1216	Auxiliary hand lifter screw.
N	1228	Presser foot chaining-off finger screw.
N	2133	Lifting lever stop screw.
N	2213	Lifting lever bracket screw.
N	2214	Presser bar lifter hinge screw.
N	2237	Feed bar hinge pin collar set screw.
N	2285	Lifting lever hinge screw.
N	2308	Presser foot set screw.
N	2371	Pressure regulating thumb screw.
N	4234	Cloth guide finger set screw.
N	5541	Presser lever stopper screw.
N	7143	Presser lever screw stud eccentric.
N	7650	Feed bar hinge pin set screw.
N	37048	Presser regulating spring guide pin.
N	37065	Presser regulating spring.
N	37144	Presser bar lifter.
N	37145	Lifting lever bracket.
N	37146	Lifting lever.
N	37147	Lifting lever spring.
N	37148	Presser lever stopper.
N	37821	Cloth guide.
N	37822	Auxiliary cloth guide.
N	37823	Cloth guide finger.
N	37825	Feed lifting bracket.
N	37826	Feed bar hinge pin.
N	37827	Feed bar hinge pin collar.
N	37848	Presser foot complete.
N	37849	Presser foot. (body only)
N	37850	Presser foot chaining-off finger.
N	37885	Presser lever.
N	37886	Auxiliary hand lifter.

PLATE No.6

FEEDING MECHANISM

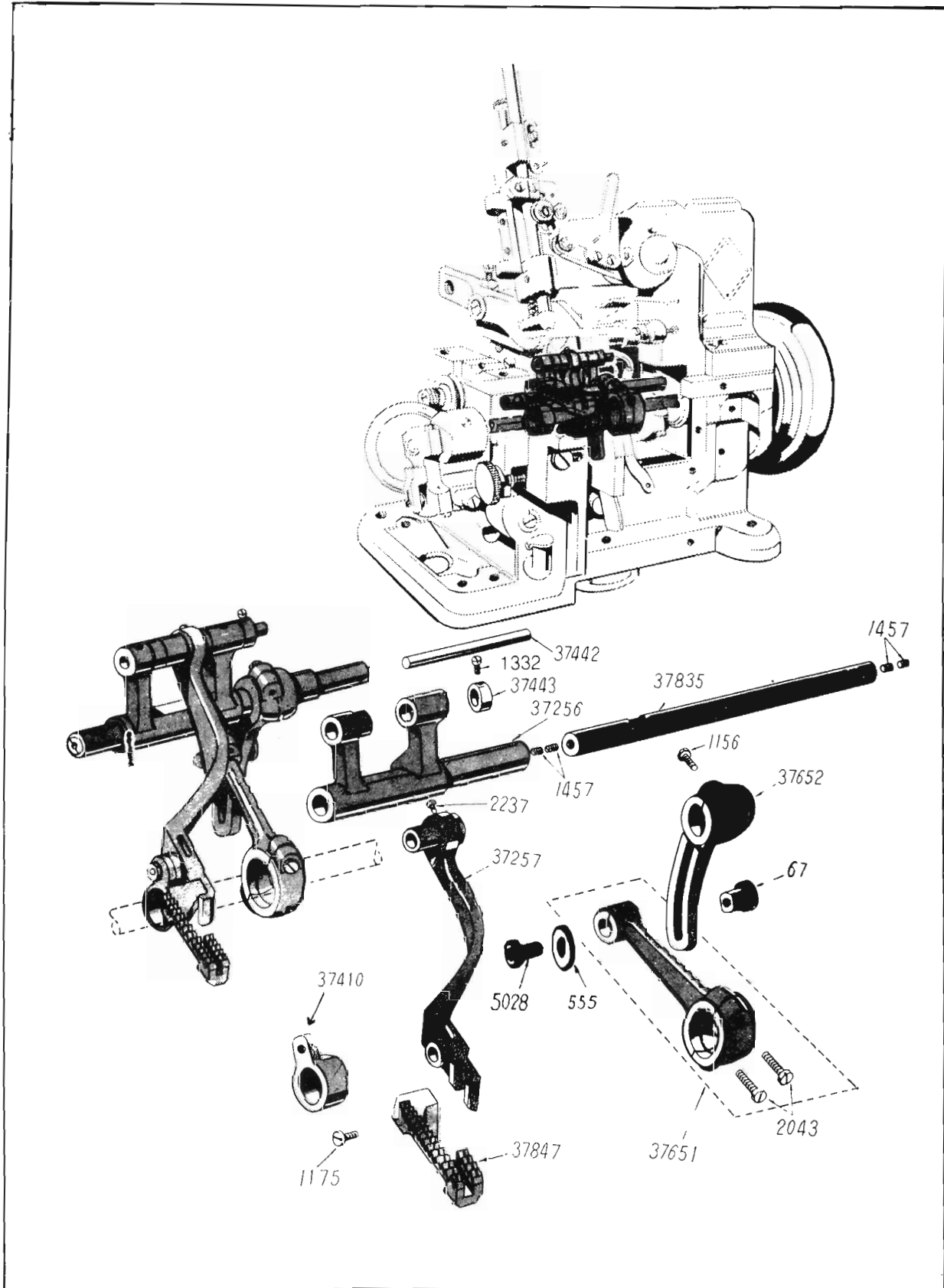

PLATE No. 6

N	67	Feed regulator hinge screw nut.
N	555	Feed regulator hinge screw washer.
N	1156	Feed regulator clamping screw.
N	1175	Feed dog screw.
N	1332	Feed bar hinge pin collar set screw.
N	1457	Looper (right hand) lever hinge pin cap screw.
N	1998	Feed connecting rod stop screw.
N	2043	Feed connecting rod cap screw.
N	2237	Feed bar hinge pin set screw.
N	2367	Feed regulator screw stud.
N	37256	Feed rock shaft.
N	37257	Feed bar
N	37410	Feed lifting eccentric connection complete set.
N	37442	Feed bar hinge pin.
N	37443	Feed bar hinge pin collar.
N	37651	Feed connecting rod complete set.
N	37652	Feed regulator.
N	37835	Feed rock shaft hinge pin.
N	37847	Feed dog.

PLATE No.7

LOOPERS MECHANISM

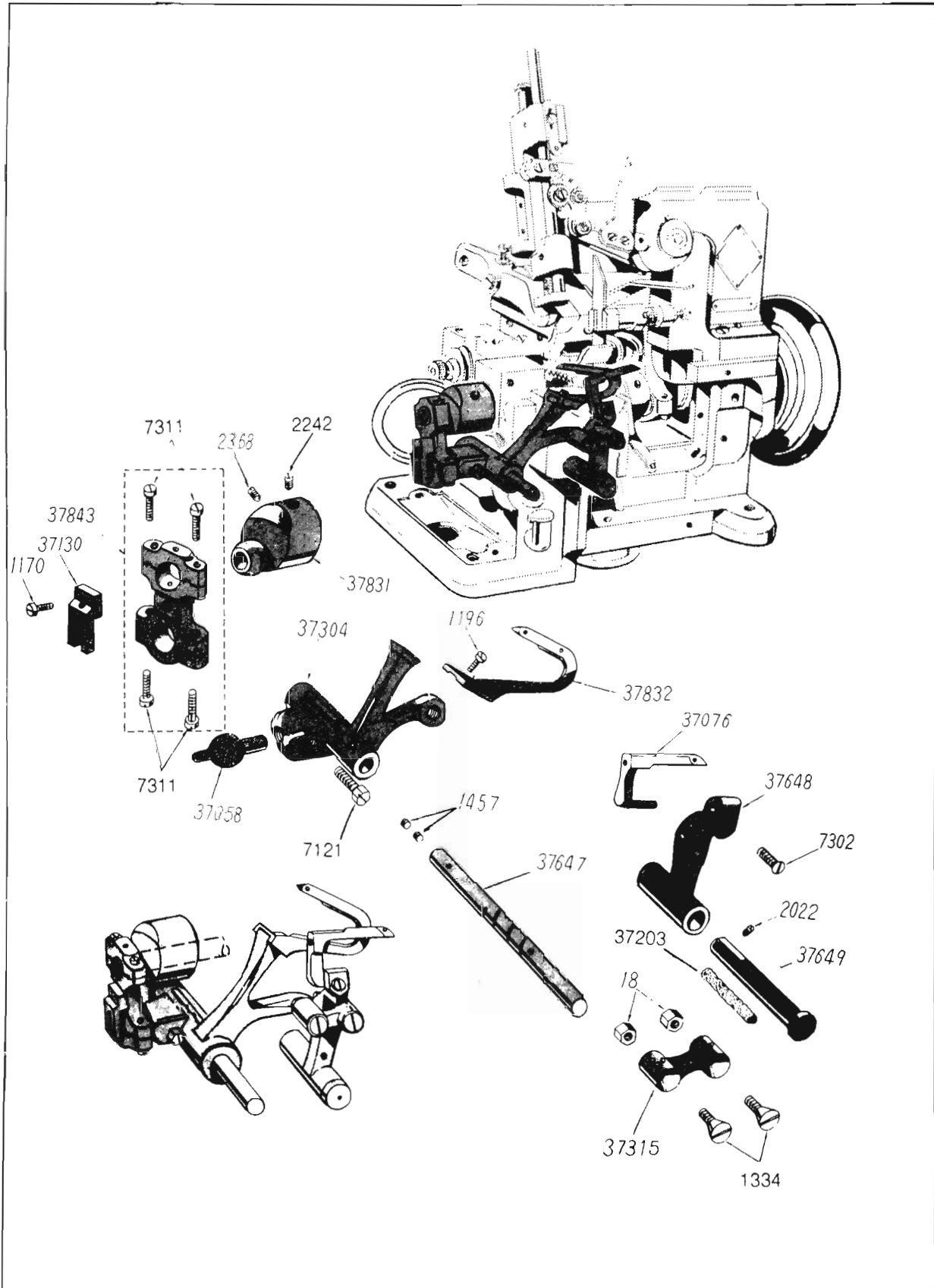

PLATE No. 7

N	18	Looper (left hand) lever connecting link hinge screw nut.
N	1170	Looper (right hand) lever connection guide set screw.
N	1196	Looper (right hand) screw.
N	1334	Looper (left hand) lever connecting link hinge screw.
N	1457	Looper (right hand) lever hinge pin cap screw.
N	2022	Looper (right hand) lever hinge pin bushing set screw.
N	2242	Frame rotary shaft crank set screw.
N	2368	Frame rotary shaft crank position screw.
N	7121	Looper (right hand) lever ball stud set screw.
N	7302	Looper (left hand) lever clamping screw.
N	7311	Looper (left hand) lever connecting rod cap screw.
N	37058	Looper (right hand) lever ball stud.
N	37076	Looper (left hand).
N	37130	Looper (right hand) lever connection guide.
N	37203	Oil wick.
N	37304	Looper (right hand) lever.
N	37305	Looper (left hand) connecting link.
N	37647	Looper (right hand) lever hinge pin.
N	37648	Looper (left hand) lever.
N	37649	Looper (left hand) lever hinge stud
N	37831	Frame rotary shaft crank.
N	37832	Looper (right hand).
N	37843	Looper (left hand) lever connecting rod complete set.

PLATE No.8

CAM, BUSHINGS AND SHAFTS

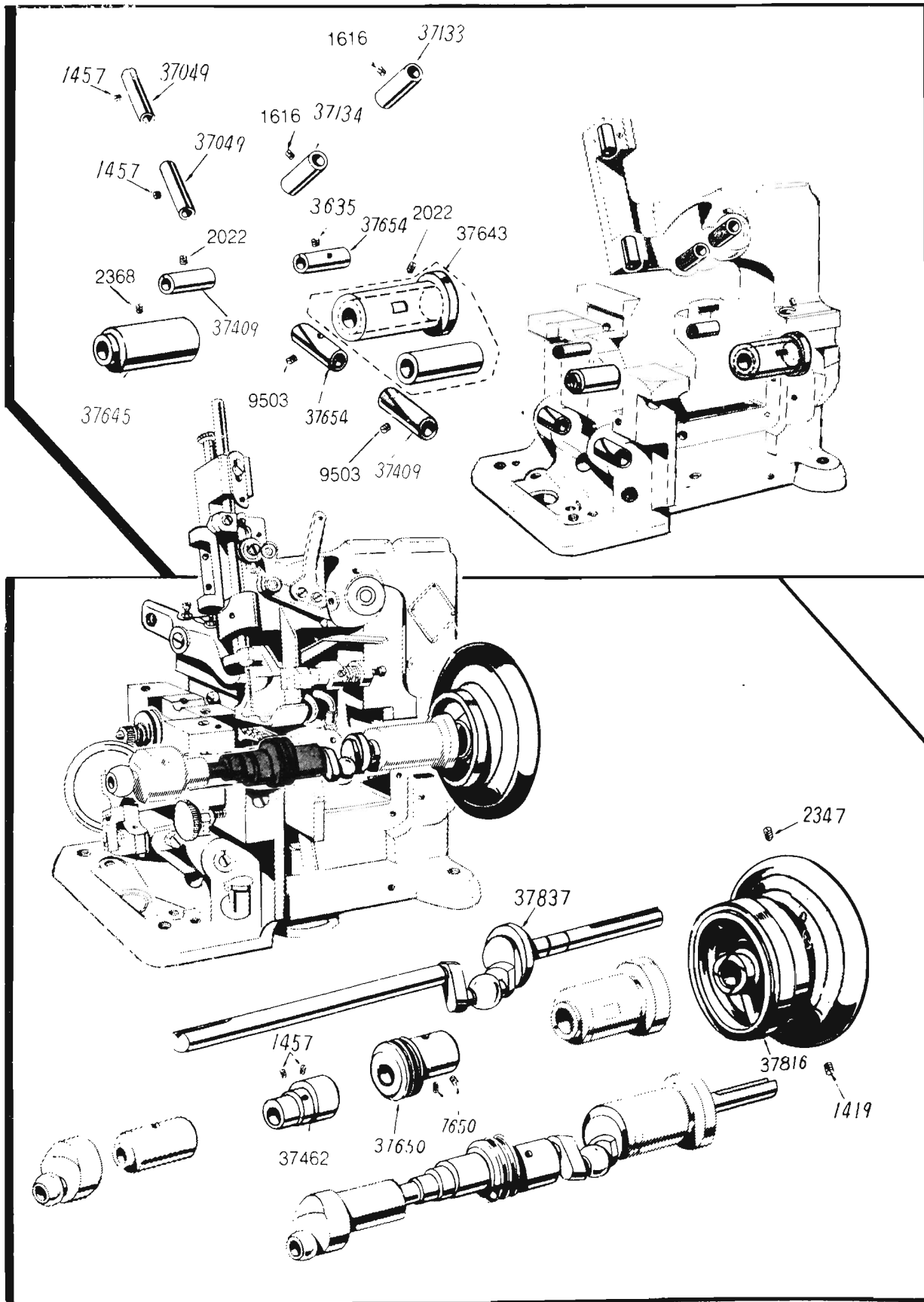

PLATE No. 8

N	1419	Balance wheel set screw.
N	1457	Feed lifting eccentric set screw.
N	1457	Needle bar busing set screw.
N	1616	Needle bar crank shaf. bushing set screw.
N	2022	Frame rotary shaft bushing (right) set screw.
N	2022	Feed rock shaft hinge pin bushing set screw.
N	2347	Balance wheel position screw.
N	2368	Frame rotary shaft bushing (left) set screw.
N	7650	Feed eccentric set screw.
N	9503	Looper (right hand) lever hinge pin bushing set screw.
N	37049	Needle bar bushing.
N	37133	Needle bar crank shaft bushing (front).
N	37134	Needle bar crank shaft bushing (rear).
N	37409	Feed rock shaft hinge pin bushing (left).
N	37409	Looper (right hand) lever hinge pin bushing (front).
N	37462	Feed lifting eccentric.
N	37643	Frame rotary shaft bushing (right) outer race.
N	37644	Frame rotary shaft bushing (right).
N	37645	Frame rotary shaft bushing (left).
N	37650	Feed eccentric.
N	37654	Looper (right hand) lever hinge pin bushing (rear).
N	37654	Feed rock shaft hinge pin bushing (right).
N	37816	Balance wheel.
N	37837	Frame rotary shaft complete set.

PLATE No.9

LUBRICATION PARTS

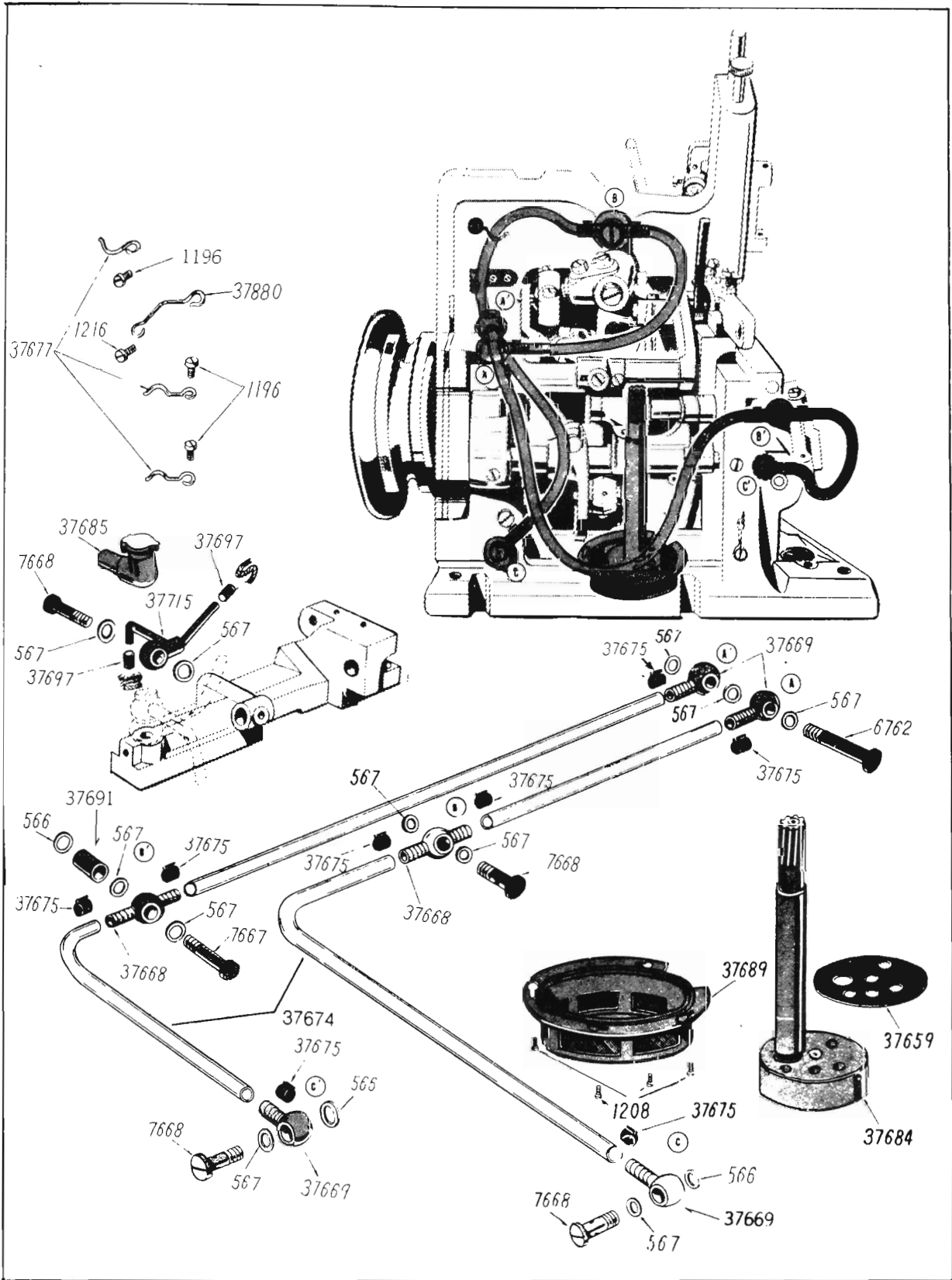

PLATE No. 9

N	566	Oil pipe fitting washer.
N	567	Oil pipe fitting washer.
N	1196	Oil tube holder (small) set screw.
N	1208	Oil pump filter frame set screw.
N	1216	Oil tube holder (large) set screw.
N	6762	Oil pipe fitting bolt (long).
N	7667	Oil pipe fitting bolt (medium).
N	7668	Oil pipe fitting bolt (short).
N	37659	Oil pump cover gasket.
N	37668	Oil pipe fitting two way end.
N	37669	Oil pipe fitting one way end.
N	37674	Oil tube (vinyl).
N	37675	Oil tube clamp.
N	37677	Oil tube holder (small).
N	37684	Oil pump complete set.
N	37685	Oil cup.
N	37686	Oil check valve tube.
N	37687	Oil check valve ball.
N	37688	Oil check valve ball pin.
N	37689	Oil filter complete set.
N	37691	Oil tube joint link.
N	37697	Oil focal point end tube (vinyl).
N	37715	Oil focal point.
N	37880	Oil tube holder (large).

PLATE No.10 SPECIAL PARTS

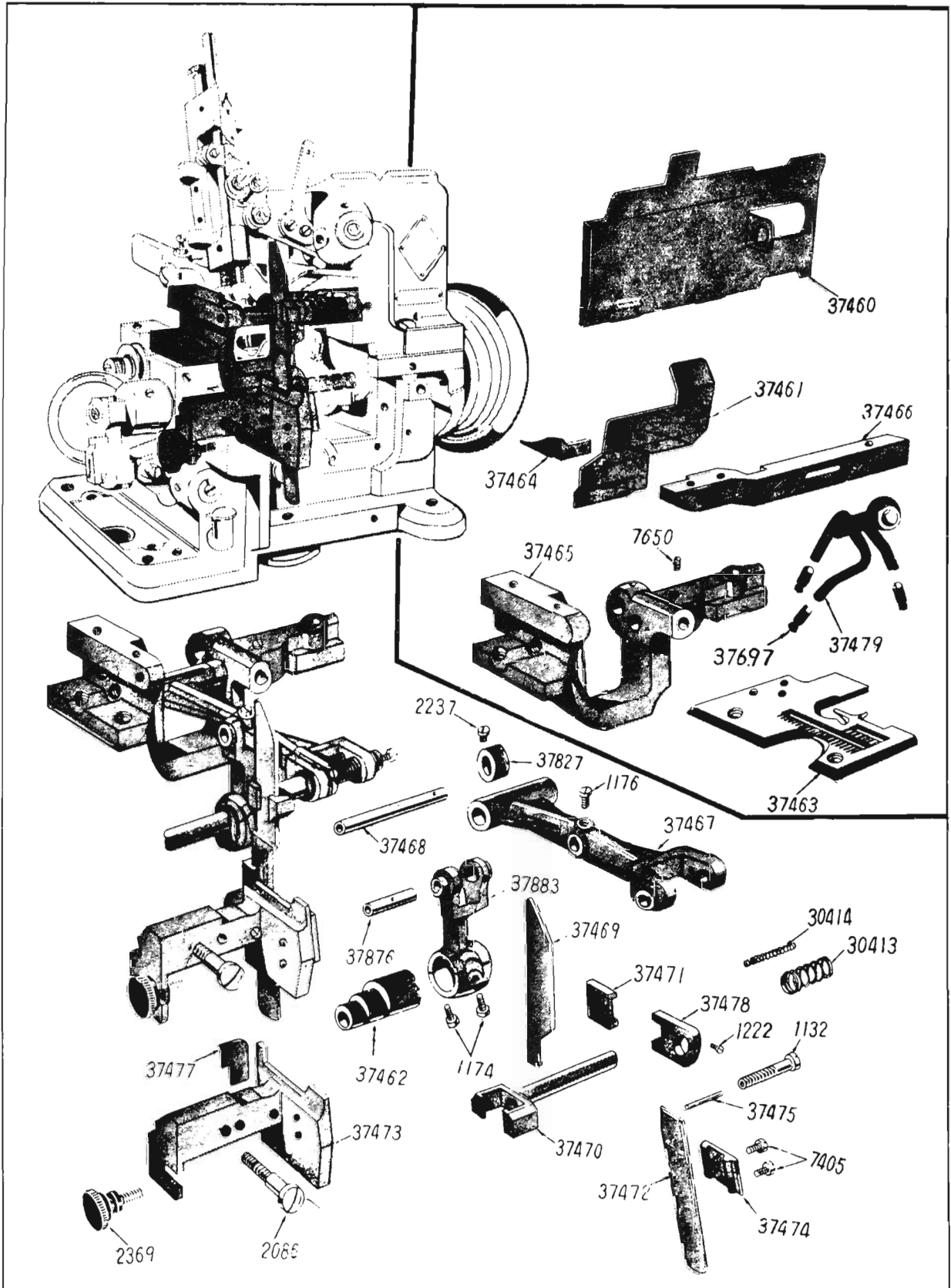

PLATE No.10

N 1132	Knife (movable) holder screw.
N 1174	Knife (movable) lever connection cap screw.
N 1176	Knife (movable) lever hinge pin set screw.
N 1222	Knife (movable) holder guide set screw.
N 2086	Knife (stationary) holder screw.
N 2237	Knife (movable) lever end hinge shaft collar set screw.
N 2369	Knife (stationary) holder regulating thumb screw.
N 7405	Knife (stationary) position plate screw.
N 7650	Knife (movable) lever end hinge shaft set screw.
N 30413	Knife (movable) holder spring (large).
N 30414	Knife (movable) holder spring (small).
N 37460	Frame side cover.
N 37461	Chip guard.
N 37462	Feed lifting eccentric.
N 37463	Throat plate.
N 37464	Auxiliary chaining-off finger.
N 37465	Knife (movable) lever bracket.
N 37466	Chip guard extension holder.
N 37467	Knife (movable) lever.
N 37468	Knife (movable) lever end hinge shaft.
N 37469	Knife (movable).
N 37470	Knife (movable) holder.
N 37471	Knife (movable) holder gib.
N 37472	Knife (stationary).
N 37473	Knife (stationary) holder.
N 37474	Knife (stationary) position plate.
N 37475	Knife (movable) holder extension pin.
N 37477	Needle guard.
N 37478	Knife (movable) holder guide.
N 37827	Knife (movable) lever end hinge shaft collar.
N 37876	Knife (movable) lever hinge pin.
N 37883	Knife (movable) lever connection.
N 37479	Oil focl point
N 37497	Wick for 37479

INDEX

PLATE No.	PARTS No.	PLATE No.	PARTS No.	PLATE No.	PARTS No.	PLATE No.	PARTS No.
7	18	4	4435	7	37304	9	37689
5	44	4	4442	7	37305	9	37691
3	56	1	5342	3	37307	2	37692
4	62	5	5541	8	37409	9	37697
6	67	3	6531	6	37410	2	37699
1	144	9	6762	6	37442	9	37715
3	331	1	7006	6	37443	4	37756
5	530	4	7120	8	37462	3	37791
2	531	7	7121	2	37540	4	37800
5	532	4	7128	1	37604	1	37804
1	541	5	7143	1	37605	2	37805
1 & 5	554	7	7302	1	37606	1	37806
6	555	4 & 7	7311	1	37607	1	37808
2	562	4	7564	1	37609	1	37809
9	566	1	7605	1	37610	1	37810
9	567	1	7609	1	37611	2	37811
2	568	1	7616	1	37612	3	37812
5	569	1 & 2	7618	1	37613	3	37813
2	578	2	7619	1	37616	3	37814
3	1092	5, 8	7650	1	37617	8	37816
3	1111	9	7667	1	37618	4	37817
5 & 6	1156	9	7668	2	37620	4	37818
4 & 7	1170	2	7678	1	37622	5	37821
1, 2, 6	1175	2	7763	2	37624	5	37822
1, 3, 7, 9	1196	3	7817	2	37626	5	37823
3 & 5	1202	3	7904	2	37627	4	37824
2 & 9	1208	2	8139	3	37631	5	37825
3, 5, 9	1216	4	9322	3	37632	5	37826
1	1218	4	9417	3	37634	5	37827
3	1227	8	9503	3	37635	7	37831
5	1228	1	37008	3	37636	7	37832
3	1231	5	37048	8	37643	3	37833
6	1332	8	37049	8	37644	6	37835
7	1334	4	37057	8	37645	8	37837
8	1419	7	37058	3	37646	2	37842
3, 6, 7, 8	1457	3	37060	7	37647	7	37843
2	1613	4	37062	7	37648	4	37845
8	1616	5	37065	7	37649	4	37846
4	1732	7	37076	8	37650	6	37847
3	1817	3	37101	6	37651	5	37848
6	1998	3	37103	6	37652	5	37849
7 & 8	2022	3	37107	8	37654	5	37850
6	2043	3	37108	9	37659	9	37880
4	2086	3	37109	9	37668	5	37885
5	2133	3	37113	9	37669	5	37886
5	2213	4 & 7	37130	9	37674	4	90320
5	2214	4	37132	9	37675	4	90321
2, 5, 6	2237	8	37133	9	37677	3	90831
7	2242	8	37134	2	37678		
5	2285	5	37144	2	37679		
5	2308	5	37145	2	37680		
8	2347	5	37146	2	37681		
7 & 8	2368	5	37147	9	37684		
5	2371	5	37148	9	37685		
1	2419	7	37203	9	37686		
5	4243	6	37256	9	37687		
4	3635	6	37257	9	37688		